

- The New Radial Leaded devices are designed to provide different products with 6 to 16 volts with a maximum 40A short circuit rating.
- Applications: This new radial leaded product series is ideal for computers and peripherals, and meet all USB over-current protection requirements.
- Agency Approval: UL/ CSA File #E201431

TÜV Certificate #R50103284

ELECTRICAL CHARACTERISTICS

Part Number	I _{hold} (A)	I _{trip} (A)	V _{max} (Vdc)	I _{max} (A)	P _d ^{typ.} (W)	Maximum Time To Trip		Resistance		Agency Approval
						Current (A)	Time (Sec.)	R _{min} (Ω)	R _{1max} (Ω)	
RLD06P075BF	0.75	1.30	6	40	0.3	8.00	0.4	0.100	0.230	UL/CSA/TÜV
RLD06P120BF	1.20	2.00	6	40	0.6	8.00	0.5	0.065	0.140	UL/CSA/TÜV
RLD06P155BF	1.55	2.70	6	40	0.6	7.75	2.2	0.040	0.100	UL/CSA/TÜV
RLD16P090BF	0.90	1.80	16	40	0.6	8.00	1.2	0.070	0.180	UL/CSA/TÜV
RLD16P110BF	1.10	2.20	16	40	0.7	8.00	2.3	0.050	0.140	UL/CSA/TÜV
RLD16P135BF	1.35	2.70	16	40	0.8	8.00	4.5	0.040	0.120	UL/CSA/TÜV
RLD16P160BF	1.60	3.20	16	40	0.9	8.00	9.0	0.030	0.110	UL/CSA/TÜV
RLD16P185BF	1.85	3.70	16	40	1.0	8.00	10.0	0.030	0.090	UL/CSA/TÜV
RLD16P250BF	2.50	5.00	16	40	1.2	8.00	40.0	0.020	0.060	UL/CSA/TÜV

Note: I_{hold} = Hold current: maximum current device will pass without tripping in 23°C still air.

I_{trip} = Trip current: minimum current at which the device will trip in 23°C still air.

V_{max} = Maximum voltage device can withstand without damage at rated current (I_{max})

I_{max} = Maximum fault current device can withstand without damage at rated voltage (V_{max})

P_d = Power dissipated from device when in the tripped state at 23°C still air.

R_{min} = Minimum resistance of device in initial (un-soldered) state.

R_{1max} = Maximum resistance of device at 23°C measured one hour after tripping.

Caution: Operation beyond the specified rating may result in damage and possible arcing and flame.

Recognitions: UL, CSA, TUV recognized.

© Specifications are subject to change without notice.

How to Select a Polymer PTC fuse:

- (1) Determine the following operating parameters for the circuits:
 - (A) Normal Operating Current (I hold)
 - (B) Maximum Circuit Voltage (V max)
 - (C) Maximum Interrupt Current (I max)
 - (D) Normal Operating Temperature (min^{°C}/max^{°C})
- (2) Select the device form factor and dimension suitable for the application:
 - Surface Mount Device (SMD Series)
 - Radial Leaded Device (RLD Series)
 - Axial Leaded Strap Device (STD Series)
 - Other Custom-designed Device (Disc/Chip)
- (3) Compare the maximum ratings for V max and I max of the PTC device with the circuit in application and make sure that the circuit's requirement does not exceed the device ratings.
- (4) Check that the PTC device's trip time (time-to-trip) will protect the circuit.
- (5) Verify that the circuit operating temperatures are within the PTC device's normal operating temperature range.
- (6) Verify the performance and suitability of the chosen PTC device in the application.

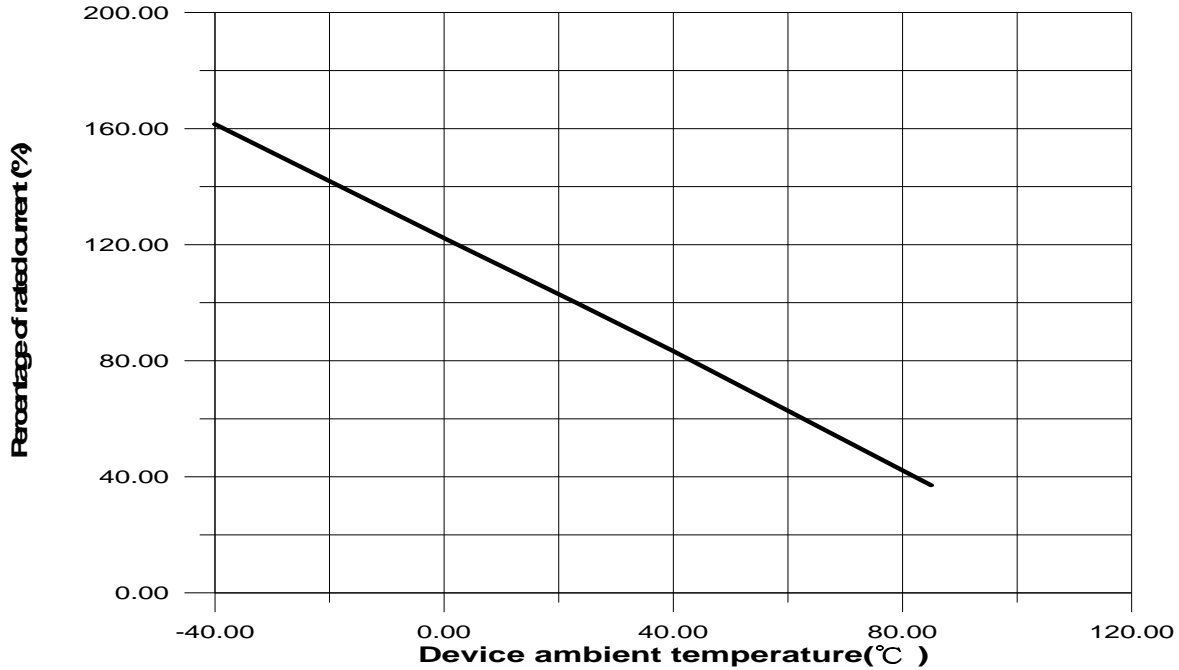
THERMAL DERATING CURVE FOR RLD FOR USB SERIES

THERMAL DERATING CHART FOR UBS SERIES – I_{hold} (Amps)

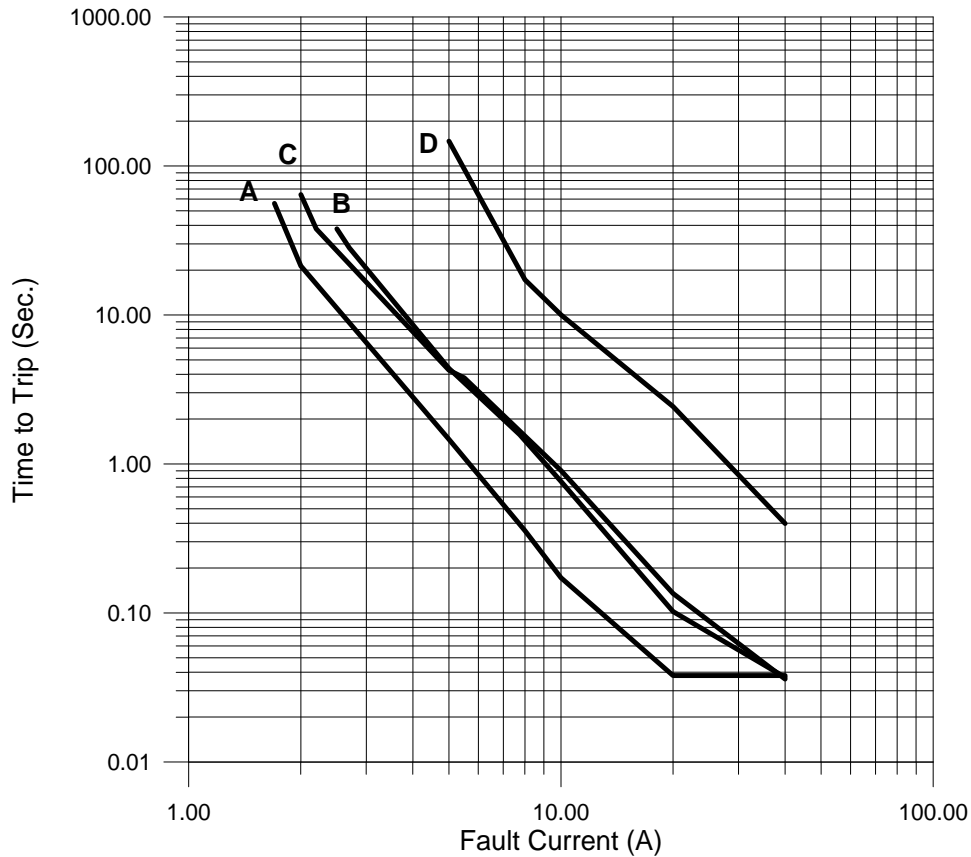
Model	Ambient Operation Temperature								
	-40°C	-20°C	0°C	23°C	40°C	50°C	60°C	70°C	85°C
RLD06P075BF	1.05	0.95	0.85	0.75	0.65	0.60	0.55	0.50	0.43
RLD06P120BF	1.69	1.52	1.36	1.20	1.04	0.96	0.88	0.80	0.68
RLD06P155BF	2.17	1.96	1.75	1.55	1.34	1.24	1.13	1.03	0.88
RLD16P090BF	1.31	1.17	1.04	0.90	0.75	0.69	0.61	0.55	0.47
RLD16P110BF	1.60	1.43	1.27	1.10	1.00	0.92	0.75	0.67	0.57
RLD16P135BF	1.96	1.76	1.55	1.35	1.12	1.04	0.92	0.82	0.70
RLD16P160BF	2.32	2.08	1.84	1.60	1.33	1.23	1.09	0.98	0.83
RLD16P185BF	2.68	2.41	2.13	1.85	1.54	1.42	1.26	1.13	0.96
RLD16P250BF	3.63	3.25	2.88	2.50	2.08	1.93	1.70	1.53	1.30

AVERAGE TIME-CURRENT CURVE FOR RLD06/16V SERIES

A=RLD06P120BF
 B=RLD06P155BF
 C=RLD16P110BF
 D=RLD16P250BF

PART NUMBERING SYSTEM

RLD □□ P □□□ □ F

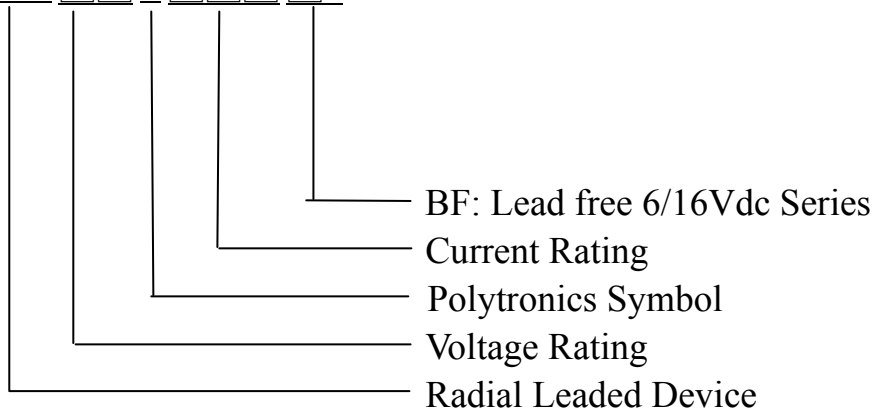

聚鼎科技股份有限公司 Polytronics Technology Corp.

新竹市科學工業園區工業東四路 24-1 號 24-1, Industry E.4th Rd. Science Park, Hsinchu, Taiwan. TEL:+886-3-5643931 FAX:+886-3-5644624

E-mail: sales@pttc.com.tw [Http://www.pttc.com.tw](http://www.pttc.com.tw)

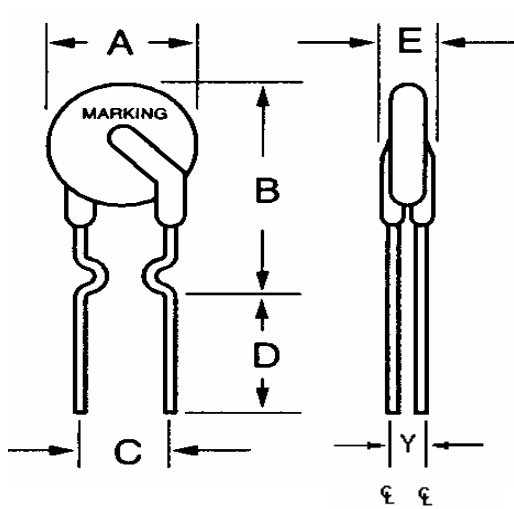
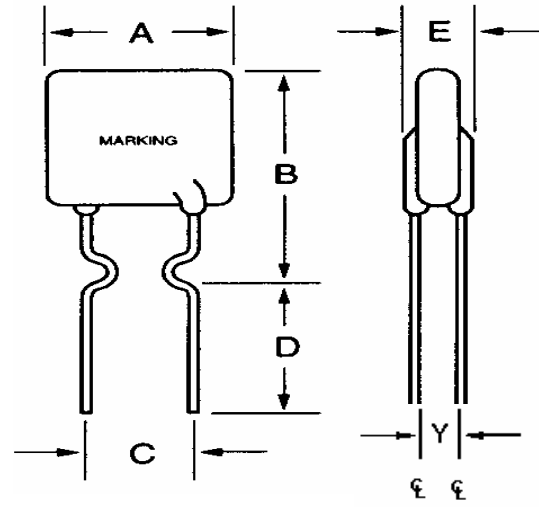

Figure 1

Figure 2
PHYSICAL DIMENSIONS (mm)

Part Number	Figure	A (max.)	B (max.)	C (typ.)	D (min.)	E (max.)	Y (typ.)	Physical Characteristics	
								Lead	Material
RLD06P075BF	1	6.9	11.4	5.1±0.7	7.6	3.0	0.9	0.51 dia.	Sn/Cu
RLD06P120BF	1	6.9	11.7	5.1±0.7	7.6	3.0	0.9	0.51 dia.	Sn/CuFe
RLD06P155BF	1	6.9	11.7	5.1±0.7	7.6	3.0	0.9	0.51 dia.	Sn/CuFe
RLD16P090BF	2	7.4	12.2	5.1±0.7	7.6	3.0	1.0	0.51 dia.	Sn/CuFe
RLD16P110BF	2	7.4	14.2	5.1±0.7	7.6	3.0	1.0	0.51 dia.	Sn/CuFe
RLD16P135BF	2	8.9	13.5	5.1±0.7	7.6	3.0	1.0	0.51 dia.	Sn/CuFe
RLD16P160BF	2	8.9	15.2	5.1±0.7	7.6	3.0	1.0	0.51 dia.	Sn/CuFe
RLD16P185BF	2	10.2	15.7	5.1±0.7	7.6	3.0	1.0	0.51 dia.	Sn/CuFe
RLD16P250BF	2	11.4	18.3	5.1±0.7	7.6	3.0	1.0	0.51 dia.	Sn/Cu

©Specifications are subject to change without notice.

ENVIRONMENTAL SPECIFICATIONS

Operating Temperature	-40°C to +85°C	
Maximum Device Surface Temperature in Tripped State	125°C	
Passive Aging	+85°C, 1000 hours	±5% typical resistance change
Humidity Aging	+85°C, 85%R.H. 1000 hours	±5% typical resistance change
Thermal Shock	+85°C to -40°C 10 times	±5% typical resistance change
Solvent Resistance	MIL-STD-202, Method 215F	No change
Storage Condition	0°C~35°C, ≤80%RH	

PHYSICAL SPECIFICATIONS

Lead Material	P090BF-P250BF: Tin-plated copper clad steel P075BF: Tin-plated copper
Soldering Characteristics	Solderability per MIL-STD-202, Method 208E
Insulating Material	Cured, flame retardant epoxy polymer meets UL94V-0 requirements.
Device Labeling	Marked with the letter "P", voltage, amperage rating, and lot number.

WAVE SOLDERING INFORMATION

Pre-Heating Zone	Refer to the condition recommended by the flux manufacturer. Max. ramping rate should not exceed 4°C/Sec.
Soldering Zone	Max. solder temperature should not exceed 260°C
Cooling Zone	Cooling by natural convection in air.

◎Specifications are subject to change without notice.

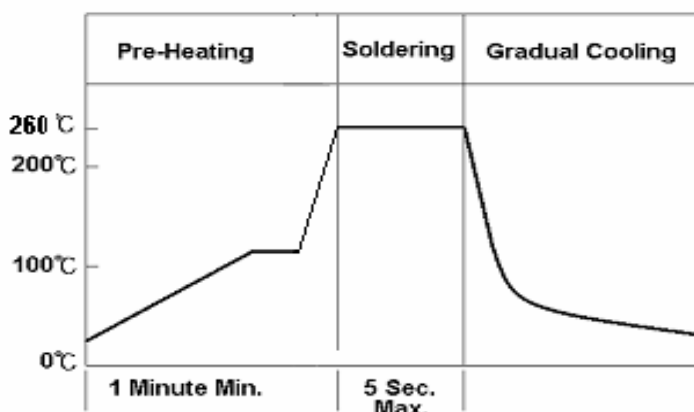

聚鼎科技股份有限公司 Polytronics Technology Corp.

新竹市科學工業園區工業東四路 24-1 號 24-1, Industry E.4th Rd. Science Park, Hsinchu, Taiwan. TEL:+886-3-5643931 FAX:+886-3-5644624

E-mail: sales@pttc.com.tw [Http://www.pttc.com.tw](http://www.pttc.com.tw)

TAPE AND REEL SPECIFICATIONS

Product availability: RLD06P075BF, RLD06P120BF, RLD06P155BF

Devices taped using EIA468-B/IE286-2 standards. See table below and Figures 1 and 2 for details.

Dimension Description	EIA mark	IEC Mark	Dimensions	
			Dim.(mm)	Tol.(mm)
Carrier tape width	W	W	18	-0.5/+1.0
Hold down tape width: 06P075BF-06P155BF	W ₄	W ₀	11	min.
Top distance between tape edges	W ₆	W ₂	3	max.
Sprocket hole position	W ₅	W ₁	9	-0.5/+0.75
Sprocket hole diameter*	D ₀	D ₀	4	+0.32
Abscissa to plane(straight lead)	H	H	18.5	+3.0
Abscissa to plane(kinked lead)	H ₀	H ₀	16	+0.5
Abscissa to top 06P075BF-06P155BF	H ₁	H ₁	32.2	max.
Overall width w/o lead protrusion 06P075BF-06P155BF	C ₁		42.5	max.
Overall width w/ lead protrusion 06P075BF-06P155BF	C ₂		43.2	max.
Lead protrusion	L ₁	l ₁	1.0	max.
Protrusion of cut out	L	L	11	max.
Protrusion beyond hold-down tape	l ₂	l ₂	Not specified	
Sprocket hole pitch 06P075BF-06P155BF	P ₀	P ₀	12.7	+0.35
Pitch tolerance			20 consecutive	+1
Device pitch: 06P075BF-06P155BF			12.7	
Tape thickness	t	t	0.9	max.
Tape thickness with splice 06P075BF-06P155BF	t ₁		2.0	max.
Splice sprocket hole alignment			0	+0.3
Body lateral deviation	Δh	Δh	0	+1.0
Body tape plane deviation	Δp	Δp	0	+1.3
Ordinate to adjacent component lead*	P ₁	P ₁	3.81	+1.0
Lead spacing* 06P075BF-06P155BF	F	F	5.08	+0.8
Reel width 06P075BF-06P155BF	w ₂	w	56	max.
Reel diameter	a	d	370	max.
Space between flanges less device	w ₁		4.75	+3.25
Arbor hole diameter	c	f	26	+12.0
Core diameter	n	h	91	max.
Box			56/372/372	max.
Consecutive missing places			None	
Empty places per reel			0.1%max.	

* Differs from EIA specification



聚鼎科技股份有限公司 Polytronics Technology Corp.

新竹市科學工業園區工業東四路 24-1 號 24-1, Industry E.4th Rd. Science Park, Hsinchu, Taiwan. TEL:+886-3-5643931 FAX:+886-3-5644624

E-mail: sales@pttc.com.tw [Http://www.pttc.com.tw](http://www.pttc.com.tw)

RLD 06P/16P BF Series Devices

2009.10.07

TAPE AND REEL SPECIFICATIONS

Product availability: RLD16P090BF-RLD16P250BF

Devices taped using EIA468-B/IE286-2 standards. See table below and Figures 1 and 2 for details.

Dimension Description	EIA Mark	IEC Mark	Dimensions	
			Dim.(mm)	Tol.(mm)
Carrier tape width	W	W	18	-0.5/+1.0
Hold down tape width: 16P090BF-16P250BF	W ₄	W ₀	11	min.
Top distance between tape edges	W ₆	W ₂	3	max.
Sprocket hole position	W ₅	W ₁	9	-0.5+0.75
Sprocket hole diameter*	D ₀	D ₀	4	-0.3
Abscissa to plane(straight lead)	H	H	18.5	+3.0
Abscissa to plane(kinked lead)	H ₀	H ₀	16	+0.5
Abscissa to top 16P090BF-16P250BF	H ₁	H ₁	32.2	Max.
Overall width w/o lead protrusion 16P090BF-16P250BF	C ₁		42.5	max.
Overall width w/ lead protrusion 16P090BF-16P250BF	C ₂		43.2	max.
Lead protrusion	L ₁	l ₁	1.0	max.
Protrusion of cut out	L	L	11	max.
Protrusion beyond hold-down tape	l ₂	l ₂	Not specified	
Sprocket hole pitch: 16P090BF-16P250BF	P ₀	P ₀	12.7	+0.35
Pitch tolerance			20 consecutive.	+1
Device pitch: 16P090BF-16P250BF			12.7	
Tape thickness	t	t	0.9	max.
Tape thickness with splice 16P090BF-16P250BF	t ₁		2.0	max.
Splice sprocket hole alignment			0	+0.3
Body lateral deviation	Δh	Δh	0	+1.0
Body tape plane deviation	Δp	Δp	0	+1.3
Ordinate to adjacent component lead*	P ₁	P ₁	3.81	+1.0
Lead spacing*: 16P090BF-16P250BF	F	F	5.08	+0.8
Reel width 16P090BF-16P250BF	w ₂	w	56	max.
Reel diameter	a	d	370	max.
Space between flanges less device	w ₁		4.75	+3.25
Arbor hole diameter	c	f	26	+12.0
Core diameter	n	h	91	Max.
Box			56/372/372	Max.
Consecutive missing places			None	
Empty places per reel			0.1%max.	

* Differs from EIA specification



聚鼎科技股份有限公司 Polytronics Technology Corp.

新竹市科學工業園區工業東四路 24-1 號 24-1, Industry E.4th Rd. Science Park, Hsinchu, Taiwan. TEL:+886-3-5643931 FAX:+886-3-5644624

E-mail: sales@pttc.com.tw [Http://www.pttc.com.tw](http://www.pttc.com.tw)

TAPE AND REEL SPECIFICATIONS

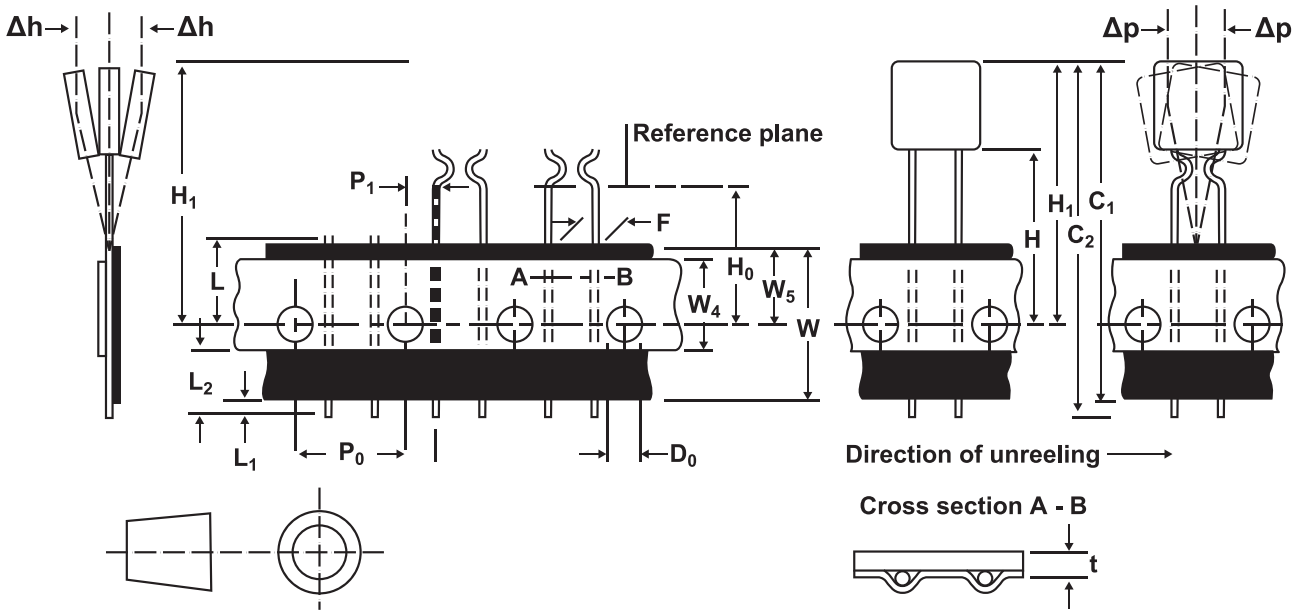

Figure 1

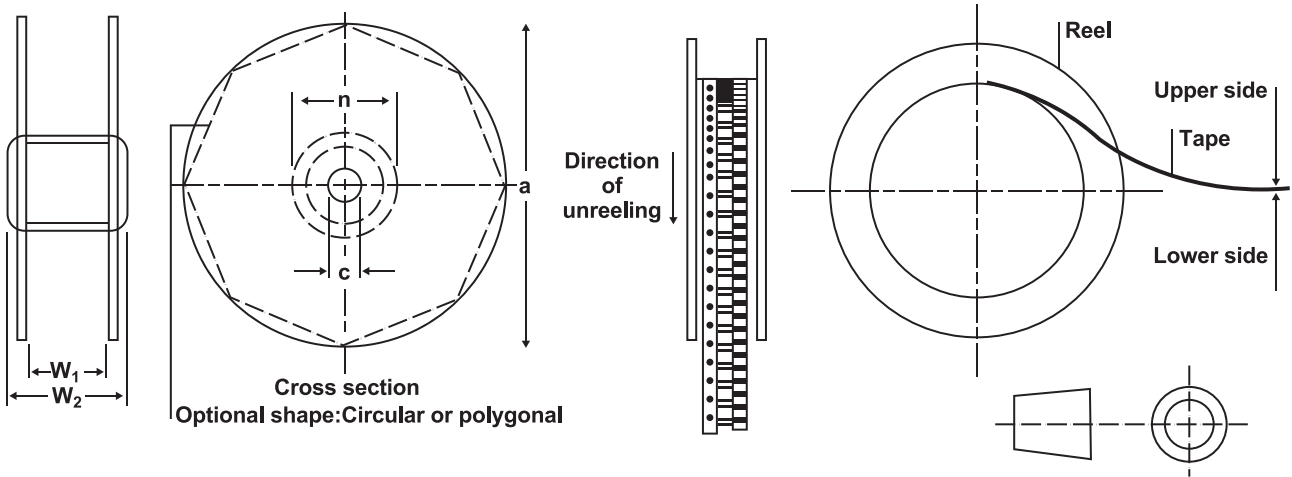
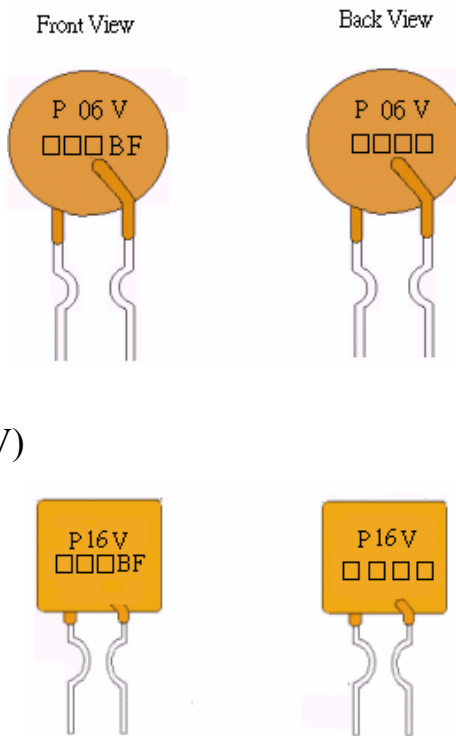
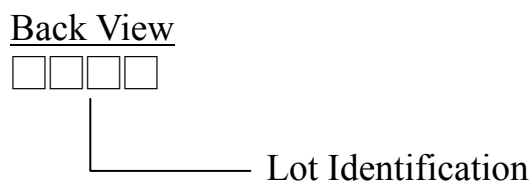
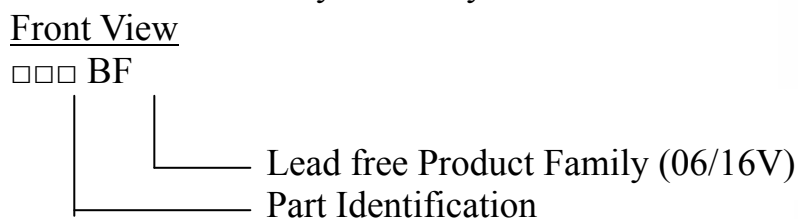
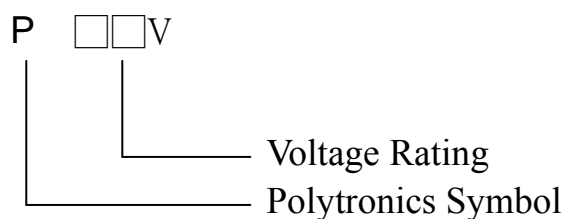

Figure 2

PACKAGING INFORMATION

Product Description	Part I.D.	Bag Quantity	Reelpack Quantity	Ammopack Quantity
RLD06P075BF	075	500	2000	2000
RLD06P120BF	120	500	2000	2000
RLD06P155BF	155	500	2000	2000
RLD16P090BF	090	500	2000	2000
RLD16P110BF	110	500	2000	2000
RLD16P135BF	135	500	2000	2000
RLD16P160BF	160	500	2000	2000
RLD16P185BF	185	500	2000	2000
RLD16P250BF	250	500	2000	2000

PART MARKING SYSTEM



CROSS REFERENCE

Polytronics/ EVERFUSE [™]	Cross Reference
	Raychem/ PolySwitch [®]
RLD06P075BF	RUSBF075
RLD06P120BF	RUSBF120
RLD06P155BF	RUSBF155
RLD16P090BF	RUSBF090
RLD16P110BF	RUSBF110
RLD16P135BF	RUSBF135
RLD16P160BF	RUSBF160
RLD16P185BF	RUSBF185
RLD16P250BF	RUSBF250

“EVERFUSE” is a registered trademark of Polytronics Technology Corp.

“PolySwitch” is a registered trademark of Raychem Corporation.

© Specifications are subject to change without notice.



聚鼎科技股份有限公司 Polytronics Technology Corp.

新竹市科學工業園區工業東四路 24-1 號 24-1, Industry E.4th Rd. Science Park, Hsinchu, Taiwan. TEL:+886-3-5643931 FAX:+886-3-5644624

E-mail: sales@pttc.com.tw [Http://www.pttc.com.tw](http://www.pttc.com.tw)