

- The Radial Leaded devices (RLD Series), a polymer-based Positive Temperature Coefficient (PTC) device to protect electrical circuits against over-current conditions with resettable feature, is fully compatible with current industrial standards.
- The Radial Leaded devices designed to provide different product series offering 30Vdc and 60Vdc voltage with a maximum 40A short circuit rating.
- Applications: The radial leaded product series is ideal for computers and peripherals, general electronics and can be applied to almost anywhere there is a low voltage power supply and a load to be protected.
- Agency Approval: UL/CSA File # E201431.

TÜV Certificate # R50103284.



### 30Vdc Series

#### ELECTRICAL CHARACTERISTICS



Part Number	I <sub>hold</sub> (A)	I <sub>trip</sub> (A)	V <sub>max</sub> (Vdc)	I <sub>max</sub> (A)	P <sub>d</sub> <sup>typ.</sup> (W)	Maximum Time To Trip		Resistance		Agency Approval
						Current (A)	Time (Sec.)	R <sub>min</sub> (Ω)	R <sub>1max</sub> (Ω)	
RLD30P090UF	0.90	1.80	30	40	0.6	4.50	5.90	0.070	0.220	UL/CSA/TÜV
RLD30P110UF	1.10	2.20	30	40	0.7	5.50	6.60	0.050	0.170	UL/CSA/TÜV
RLD30P135UF	1.35	2.70	30	40	0.8	6.75	7.30	0.040	0.130	UL/CSA/TÜV
RLD30P160UF	1.60	3.20	30	40	0.9	8.00	8.00	0.030	0.110	UL/CSA/TÜV
RLD30P185UF	1.85	3.70	30	40	1.0	9.25	8.70	0.030	0.090	UL/CSA/TÜV
RLD30P250UF	2.50	5.00	30	40	1.2	12.50	10.30	0.020	0.070	UL/CSA/TÜV
RLD30P300UF	3.00	6.00	30	40	2.0	15.00	10.80	0.020	0.080	UL/CSA/TÜV
RLD30P400UF	4.00	8.00	30	40	2.5	20.00	12.70	0.010	0.050	UL/CSA/TÜV
RLD30P500UF	5.00	10.00	30	40	3.0	25.00	14.50	0.010	0.050	UL/CSA/TÜV
RLD30P600UF	6.00	12.00	30	40	3.5	30.00	16.00	0.005	0.040	UL/CSA/TÜV
RLD30P700UF	7.00	14.00	30	40	3.8	35.00	17.50	0.005	0.030	UL/CSA/TÜV
RLD30P800UF	8.00	16.00	30	40	4.0	40.00	18.80	0.005	0.020	UL/CSA/TÜV
RLD30P900UF	9.00	18.00	30	40	4.2	40.00	20.00	0.005	0.020	UL/CSA/TÜV

Note: I<sub>hold</sub> = Hold current: maximum current device will pass without tripping in 23°C still air.

I<sub>trip</sub> = Trip current: minimum current at which the device will trip in 23°C still air.

V<sub>max</sub> = Maximum voltage device can withstand without damage at rated current (I<sub>max</sub>)

I<sub>max</sub> = Maximum fault current device can withstand without damage at rated voltage (V<sub>max</sub>)

P<sub>d</sub> = Power dissipated from device when in the tripped state at 23°C still air.

R<sub>min</sub> = Minimum resistance of device in initial (un-soldered) state.

R<sub>1max</sub> = Maximum resistance of device at 23°C measured one hour after tripping.

**Caution: Operation beyond the specified rating may result in damage and possible arcing and flame.**

**Recognitions: UL, CSA, TUV recognized.**

©Specifications are subject to change without notice.



聚鼎科技股份有限公司 Polytronics Technology Corp.

新竹市科學工業園區工業東四路 24-1 號 24-1, Industry E.4<sup>th</sup> Rd. Science Park, Hsinchu, Taiwan. TEL:+886-3-5643931 FAX:+886-3-5644624

E-mail: [sales@pttc.com.tw](mailto:sales@pttc.com.tw) [Http://www.pttc.com.tw](http://www.pttc.com.tw)

## **How to Select a Polymer PTC fuse:**

- (1) Determine the following operating parameters for the circuits:
  - (A) Normal Operating Current (I hold)
  - (B) Maximum Circuit Voltage (V max)
  - (C) Maximum Interrupt Current (I max)
  - (D) Normal Operating Temperature (min<sup>°C</sup>/max<sup>°C</sup>)
- (2) Select the device form factor and dimension suitable for the application:
  - Surface Mount Device (SMD Series)
  - Radial Leaded Device (RLD Series)
  - Axial Leaded Strap Device (STD Series)
  - Other Custom-designed Device (Disc/Chip)
- (3) Compare the maximum ratings for V max and I max of the PTC device with the circuit in application and make sure that the circuit's requirement does not exceed the device ratings.
- (4) Check that the PTC device's trip time (time-to-trip) will protect the circuit.
- (5) Verify that the circuit operating temperatures are within the PTC device's normal operating temperature range.
- (6) Verify the performance and suitability of the chosen PTC device in the application.

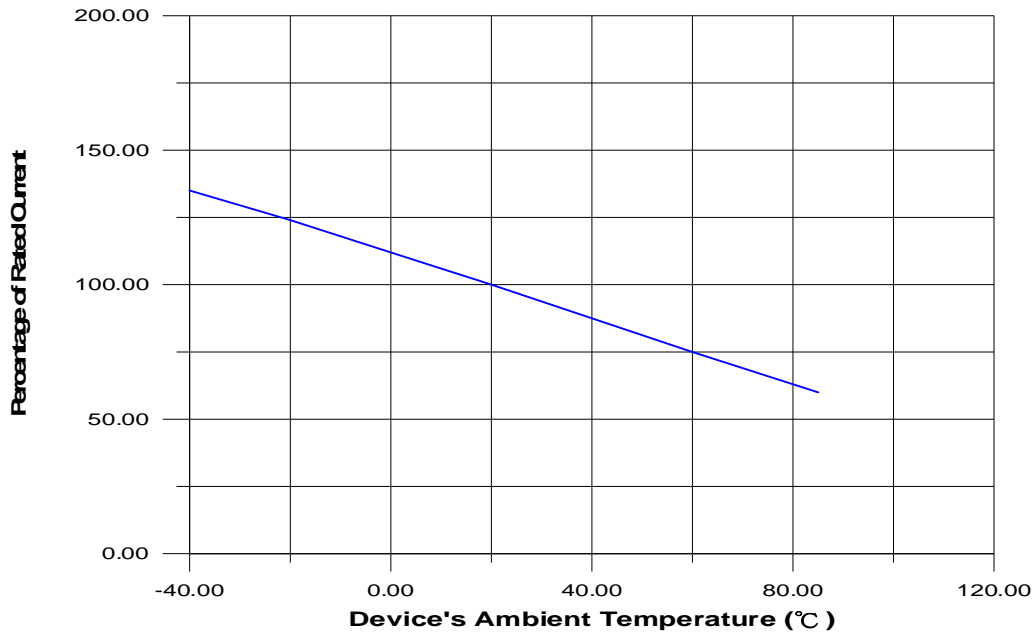
**THERMAL DERATING CURVE FOR RLD 30Vdc SERIES**

**THERMAL DERATING CHART FOR RLD30V SERIES – I<sub>hold</sub> (Amps)**

Model	Ambient Operation Temperature								
	-40°C	-20°C	0°C	23°C	40°C	50°C	60°C	70°C	85°C
RLD30P090UF	1.31	1.17	1.04	0.90	0.75	0.69	0.61	0.55	0.47
RLD30P110UF	1.60	1.43	1.27	1.10	0.91	0.85	0.75	0.67	0.57
RLD30P135UF	1.96	1.76	1.55	1.35	1.12	1.04	0.92	0.82	0.70
RLD30P160UF	2.32	2.08	1.84	1.60	1.33	1.23	1.09	0.98	0.83
RLD30P185UF	2.68	2.41	2.13	1.85	1.54	1.42	1.26	1.13	0.96
RLD30P250UF	3.63	3.25	2.88	2.50	2.08	1.93	1.70	1.53	1.30
RLD30P300UF	4.35	3.90	3.45	3.00	2.49	2.31	2.04	1.83	1.56
RLD30P400UF	5.80	5.20	4.60	4.00	3.32	3.08	2.72	2.44	2.08
RLD30P500UF	7.25	6.50	5.75	5.00	4.15	3.85	3.40	3.05	2.60
RLD30P600UF	8.70	7.80	6.90	6.00	4.98	4.62	4.08	3.66	3.12
RLD30P700UF	10.15	9.10	8.05	7.00	5.81	5.39	4.76	4.27	3.64
RLD30P800UF	11.60	10.40	9.20	8.00	6.64	6.16	5.44	4.88	4.16
RLD30P900UF	13.05	11.70	10.35	9.00	7.47	6.93	6.12	5.49	4.68

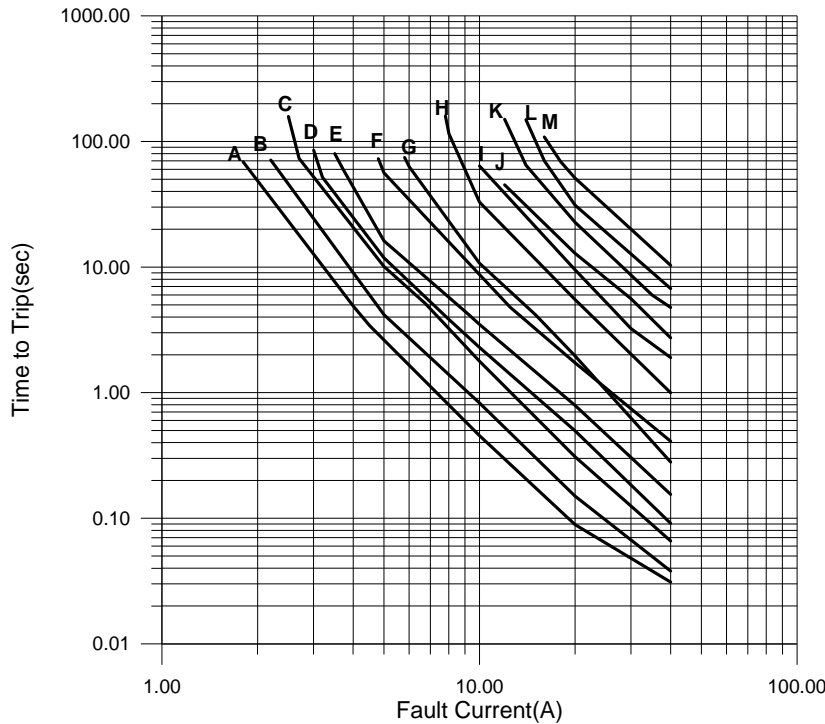

## AVERAGE TIME-CURRENT CURVE FOR RLD 30Vdc SERIES



- A=RLD30P090UF
- B= RLD30P110UF
- C=RLD30P135UF
- D= RLD30P160UF
- E=RLD30P185UF
- F=RLD30P250UF
- G=RLD30P300UF
- H=RLD30P400UF
- I=RLD30P500UF
- J=RLD30P600UF
- K=RLD30P700UF
- L=RLD30P800UF
- M=RLD30P900UF

## PART NUMBERING SYSTEM

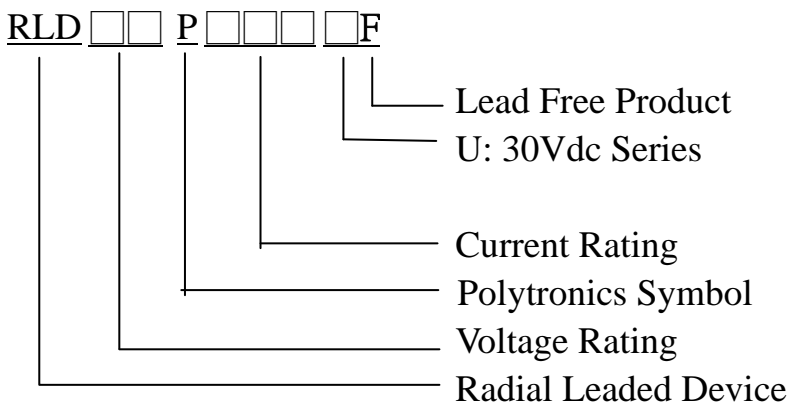

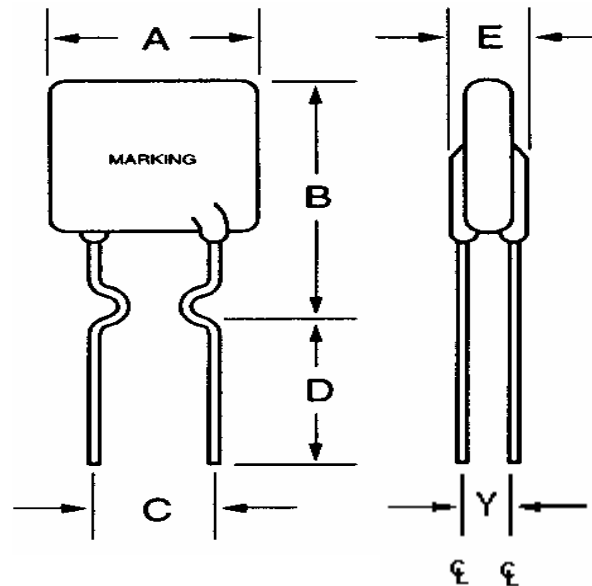
**RLD 30P Series Figure**

**PHYSICAL DIMENSIONS (mm)**

Part Number	A (max.)	B (max.)	C (typ.)	D (min.)	E (max.)	Y (typ.)	Physical Characteristics Lead	Material
RLD30P090UF	7.4	12.2	5.1±0.7	7.6	3.0	1.0	0.51 dia.	Sn/CuFe
RLD30P110UF	7.4	14.2	5.1±0.7	7.6	3.0	1.0	0.51 dia.	Sn/CuFe
RLD30P135UF	8.9	13.5	5.1±0.7	7.6	3.0	1.0	0.51 dia.	Sn/CuFe
RLD30P160UF	8.9	15.2	5.1±0.7	7.6	3.0	1.0	0.51 dia.	Sn/CuFe
RLD30P185UF	10.2	15.7	5.1±0.7	7.6	3.0	1.0	0.51 dia.	Sn/CuFe
RLD30P250UF	11.4	18.3	5.1±0.7	7.6	3.0	1.0	0.51 dia.	Sn/Cu
RLD30P300UF	11.4	19.2	5.1±0.7	7.6	3.0	1.2	0.81 dia.	Sn/Cu
RLD30P400UF	14.0	22.0	5.1±0.7	7.6	3.0	1.2	0.81 dia.	Sn/Cu
RLD30P500UF	14.0	25.6	10.2±1.0	7.6	3.0	1.2	0.81 dia.	Sn/Cu
RLD30P600UF	16.5	26.8	10.2±1.0	7.6	3.0	1.2	0.81 dia.	Sn/Cu
RLD30P700UF	19.1	28.6	10.2±1.0	7.6	3.0	1.2	0.81 dia.	Sn/Cu
RLD30P800UF	21.6	31.1	10.2±1.0	7.6	3.0	1.2	0.81 dia.	Sn/Cu
RLD30P900UF	24.1	31.6	10.2±1.0	7.6	3.0	1.2	0.81 dia.	Sn/Cu

©Specifications are subject to change without notice.



聚鼎科技股份有限公司 Polytronics Technology Corp.

 新竹市科學工業園區工業東四路 24-1 號 24-1, Industry E.4<sup>th</sup> Rd. Science Park, Hsinchu, Taiwan. TEL:+886-3-5643931 FAX:+886-3-5644624

 E-mail: [sales@ptc.com.tw](mailto:sales@ptc.com.tw) [Http://www.ptc.com.tw](http://www.ptc.com.tw)

**ENVIRONMENTAL SPECIFICATIONS**

Operating Temperature	-40°C to +85°C	
Maximum Device Surface Temperature in Tripped State	125°C	
Passive Aging	+85°C, 1000 hours	±5% typical resistance change
Humidity Aging	+85°C, 85% R.H. 1000 hours	±5% typical resistance change
Thermal Shock	+85°C to -40°C 10 times	±5% typical resistance change
Solvent Resistance	MIL-STD-202, Method 215F	No change
Storage Condition	0°C ~ 35°C, ≤ 80% RH	

**PHYSICAL SPECIFICATIONS**

Lead Material	P090UF-P250UF: Tin-plated copper clad steel P300UF-P900UF: Tin-plated copper
Soldering Characteristics	Solderability per MIL-STD-202, Method 208E
Insulating Material	Cured, flame retardant epoxy polymer meets UL94V-0 requirements.
Device Labeling	Marked with the letter "P", voltage, amperage rating, and lot number.

**WAVE SOLDERING INFORMATION**

Pre-Heating Zone	Refer to the condition recommended by the flux manufacturer. Max. ramping rate should not exceed 4°C/Sec.
Soldering Zone	Max. solder temperature should not exceed 260°C
Cooling Zone	Cooling by natural convection in air.

©Specifications are subject to change without notice.

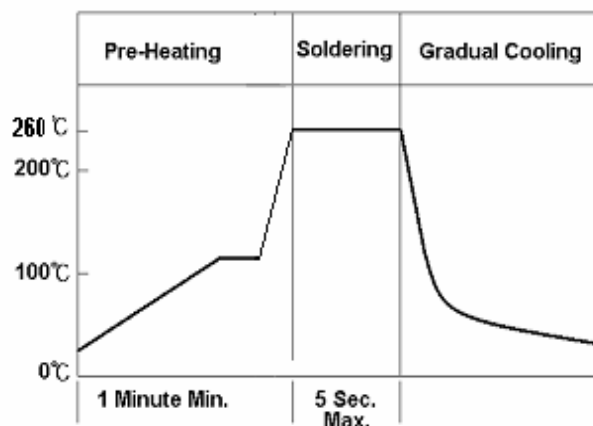

聚鼎科技股份有限公司 Polytronics Technology Corp.

新竹市科學工業園區工業東四路 24-1 號 24-1, Industry E.4<sup>th</sup> Rd. Science Park, Hsinchu, Taiwan. TEL:+886-3-5643931 FAX:+886-3-5644624

E-mail: [sales@ptc.com.tw](mailto:sales@ptc.com.tw) [Http://www.ptc.com.tw](http://www.ptc.com.tw)

# RLD 30P UF Series Devices

2009.10.07

## TAPE AND REEL SPECIFICATIONS

**Product availability: RLD30P090UF-RLD30P900UF**
**Devices taped using EIA468-B/IE286-2 standards. See table below and Figures 1 and 2 for details.**

Dimension Description	EIA mark	IEC Mark	Dimensions	
			Dim.(mm)	Tol.(mm)
Carrier tape width	W	W	18	-0.5/+1.0
Hold down tape width:	W <sub>4</sub>	W <sub>0</sub>	11	min.
Top distance between tape edges	W <sub>6</sub>	W <sub>2</sub>	3	max.
Sprocket hole position	W <sub>5</sub>	W <sub>1</sub>	9	-0.5+0.75
Sprocket hole diameter*	D <sub>0</sub>	D <sub>0</sub>	4	-0.32/+0.2
Abscissa to plane(straight lead)	H	H	18.5	+3.0
Abscissa to plane(kinked lead)	H <sub>0</sub>	H <sub>0</sub>	16	+0.5
Abscissa to top P090UF-P185UF	H <sub>1</sub>	H <sub>1</sub>	32.2	max.
Abscissa to top P250UF-P900UF			45.0	max.
Overall width w/o lead protrusion P090UF-P185UF	C <sub>1</sub>		42.5	max.
Overall width w/o lead protrusion P250UF-P900UF			56	max.
Overall width w/ lead protrusion P090UF-P185UF	C <sub>2</sub>		43.2	max.
Overall width w/ lead protrusion P250UF-P900UF			57	max.
Lead protrusion	L <sub>1</sub>	l <sub>1</sub>	1.0	max.
Protrusion of cut out	L	L	11	max.
Protrusion beyond hold-down tape	l <sub>2</sub>	l <sub>2</sub>	Not specified	
Sprocket hole pitch:P090UF-P300UF	P <sub>0</sub>	P <sub>0</sub>	12.7	+0.3
Sprocket hole pitch on P400UF-P900UF	P <sub>0</sub>	P <sub>0</sub>	25.4	+0.5
Device pitch:P090UF-P300UF			12.7	
Device pitch:P400UF-P900UF			25.4	
Pitch tolerance			20 consecutive.	+1
Tape thickness	t	t	0.9	max.
Tape thickness with splice P090UF-P250UF	t <sub>1</sub>		1.5	max.
Tape thickness with splice P300UF-P900UF	t <sub>1</sub>		2.0	max.
Splice sprocket hole alignment			0	+0.3
Body lateral deviation	Δh	Δh	0	+1.0
Body tape plane deviation	Δp	Δp	0	+1.3
Ordinate to adjacent component lead*	P <sub>1</sub>	P <sub>1</sub>	3.81	+0.7
Ordinate to adjacent component lead*			7.62	+0.7
Lead spacing:P090UF-P400UF	F	F	5.08	+0.8
Lead spacing:P500UF-P900UF	F	F	10.18	+0.8
Reel width P090UF-P185UF	w <sub>2</sub>	w	56	max.
Reel width P250UF-P900UF	w <sub>2</sub>	w	63.5	max.
Reel diameter	a	d	370	max.
Space between flanges less device*	w <sub>1</sub>		4.75	3.25/+8.25
Arbor hole diameter	c	f	26	+12.0
Core diameter*	n	h	91	max.
Box			64/372/372	max.
Consecutive missing places			None	
Empty places per reel			0.1% max.	



聚鼎科技股份有限公司 Polytronics Technology Corp.

 新竹市科學工業園區工業東四路 24-1 號 24-1, Industry E.4<sup>th</sup> Rd. Science Park, Hsinchu, Taiwan. TEL:+886-3-5643931 FAX:+886-3-5644624

 E-mail: [sales@pttc.com.tw](mailto:sales@pttc.com.tw) [Http://www.pttc.com.tw](http://www.pttc.com.tw)

### TAPE AND REEL SPECIFICATIONS

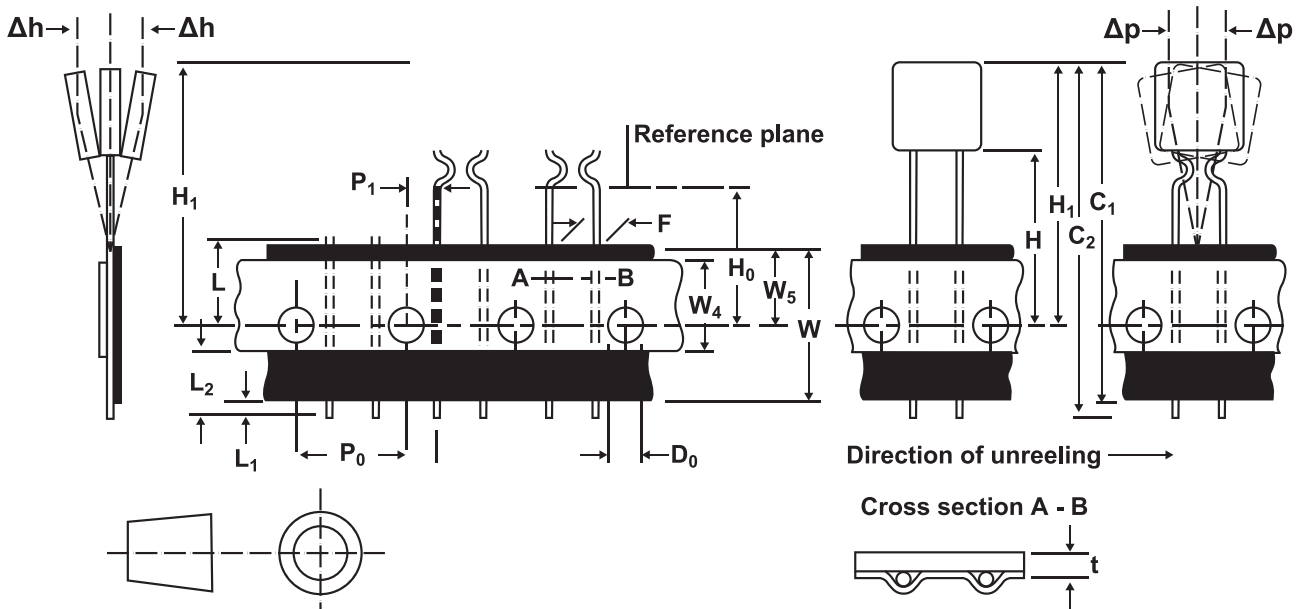

Figure 1

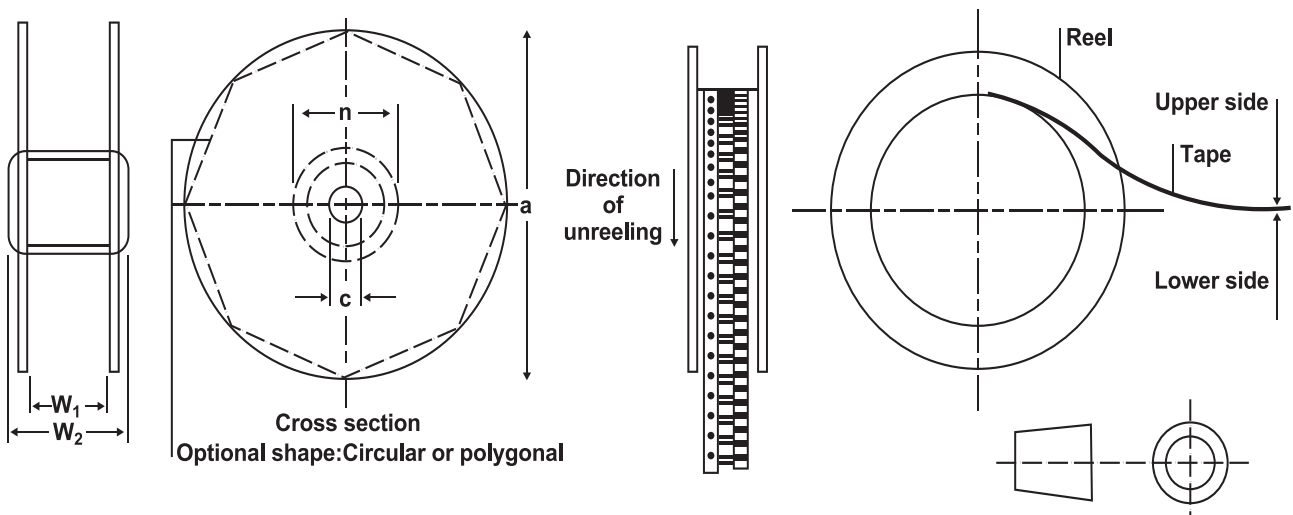

Figure 2



# RLD 30P UF Series Devices

2009.10.07

## PACKAGING INFORMATION

Product Description	Part I.D.	Bag Quantity	Reel Quantity	Ammopack Quantity
RLD30P090UF	090	500	2000	2000
RLD30P110UF	110	500	2000	2000
RLD30P135UF	135	500	2000	2000
RLD30P160UF	160	500	2000	2000
RLD30P185UF	185	500	2000	2000
RLD30P250UF	250	500	2000	2000
RLD30P300UF	300	500	2000	2000
RLD30P400UF	400	200	1000	1000
RLD30P500UF	500	200	1000	1000
RLD30P600UF	600	200	1000	1000
RLD30P700UF	700	200	1000	1000
RLD30P800UF	800	100	N/A	1000
RLD30P900UF	900	100	N/A	1000

## PART MARKING SYSTEM

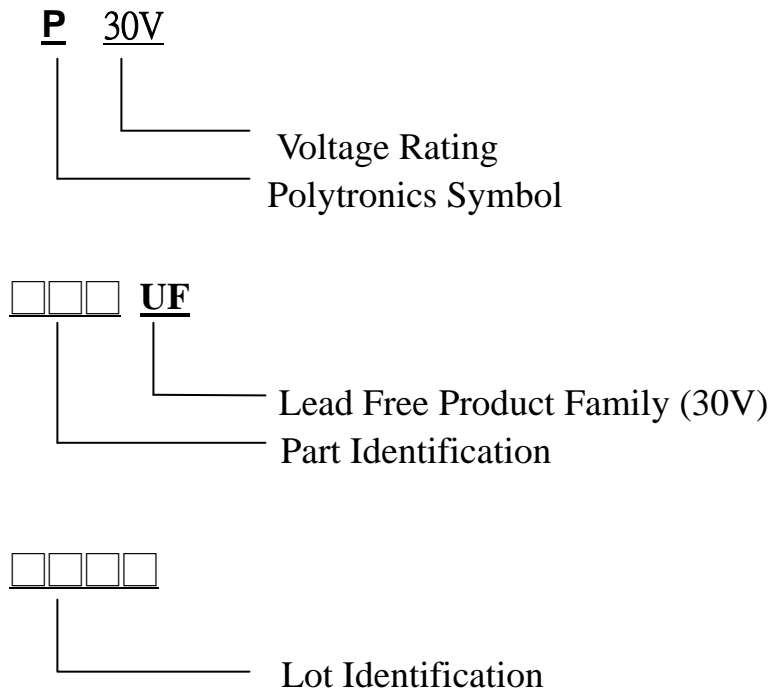

聚鼎科技股份有限公司 Polytronics Technology Corp.

 新竹市科學工業園區工業東四路 24-1 號 24-1, Industry E.4<sup>th</sup> Rd. Science Park, Hsinchu, Taiwan. TEL:+886-3-5643931 FAX:+886-3-5644624

 E-mail: [sales@pttc.com.tw](mailto:sales@pttc.com.tw) [Http://www.pttc.com.tw](http://www.pttc.com.tw)

**CROSS REFERENCE**

Polytronics/ EVERFUSE™	Cross Reference	
	Raychem/ PolySwitch®	Bourns/ Multifuse®
RLD30P090UF / RLD30P090UF-S	RUEF090 / RUEF090S	MF-R090-0-009
RLD30P110UF / RLD30P110UF-S	RUEF110 / RUEF110S	MF-R110
RLD30P135UF / RLD30P135UF-S	RUEF135 / RUEF135S	MF-R135
RLD30P160UF / RLD30P160UF-S	RUEF160 / RUEF160S	MF-R160
RLD30P185UF / RLD30P185UF-S	RUEF185 / RUEF185S	MF-R185
RLD30P250UF / RLD30P250UF-S	RUEF250 / RUEF250S	MF-R250
RLD30P300UF / RLD30P300UF-S	RUEF300K / RUEF300	MF-R300
RLD30P400UF / RLD30P400UF-S	RUEF400K / RUEF400	MF-R400
RLD30P500UF / RLD30P500UF-S	RUEF500K / RUEF500	MF-R500
RLD30P600UF / RLD30P600UF-S	RUEF600K / RUEF600	MF-R600
RLD30P700UF / RLD30P700UF-S	RUEF700K / RUEF700	MF-R700
RLD30P800UF / RLD30P800UF-S	RUEF800K / RUEF800	MF-R800
RLD30P900UF / RLD30P900UF-S	RUEF900K / RUEF900	MF-R900

“EVERFUSE” is a registered trademark of Polytronics Technology Corp.

“Multifuse” is a registered trademark of Bourns , Inc.

“PolySwitch” is a registered trademark of Raychem Corporation.

© Specifications are subject to change without notice.

